

FLUID HANDLING:

Mobile Equipment-Engine Kits

The system removes soft particles, such as soot, from engine oil and provides filtration with depth media for a constant contamination control solution at very low ISO cleanliness levels.



KEY BENEFITS:

- Dedicated depth filtration for constant contamination control
- Heavy-duty, industrial designed canisters ideal for harsh environment

The Specs

The Engine Kit:

Where It's Used

- Loader engines
- Dozer engines
- Haul truck engines
- Off-road mobile diesel engines

Selecting the Appropriate Model:

- Up to 8 cylinders: ENG-1
- 10 or more cylinders: ENG-2

Features for Each Model Include:

ENG-1

- 1 - 1000 swing bolt lid filter canister
- 1 - 50psi pressure relief valve
- 1 - Flow control orifice at inlet of canister
- 1 - 6 part, size 1000 depth filter element
- ½" & ¾" NPT plumbing connections

ENG-2

- 2 - 1000 swing bolt lid filter canisters
- 1 - 50psi pressure relief valve
- 1 - Flow control orifice at inlet of canister
- 2 - 6 part, size 1000 depth filter elements
- ½" NPT plumbing connections

NOTE: Customer to supply hose and fittings needed for machine connections.

How It Works:

The mobile equipment engine kits work by taking small amounts of oil after the OEM full flow filter and directing it through the engine kit. Oil flows through the engine kit at a set rate and is returned directly to the engine sump.

The system is designed to prevent the canisters from being emptied when the equipment is shut down, while the small amount of oil directed through the engine kit at any given time ensures the engine is never starved of oil. A pressure relief valve is also installed to prevent accidental over pressuring of the canisters during cold cranking.

Flow Diagram:

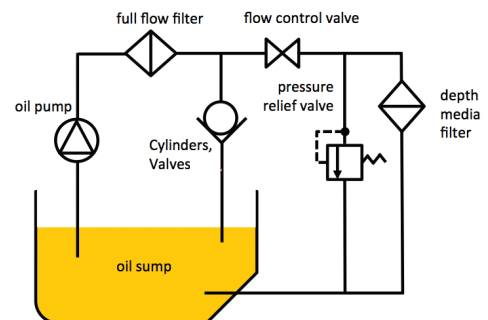

Particulate Removal Filter Media

Wound Cellulose Depth Media

Features Include:

- High-efficiency filtration at very low micron levels (≤ 1 micron)
- Ideal for filtering petroleum-based fluids
- Dirt holding capacity up to 10lbs per element
- Absorbs up to 1 gallon of water per element
- Can maintain moisture levels below 50ppm